



# SPI current status and major design initiatives current and under consideration

Alex Koifman  
Intergraph PPM  
August 6<sup>th</sup>, 2008



- SmartPlant Instrumentation Vision
- SmartPlant Instrumentation in 2007/2008
- V.2007 SP's and v.2008
- Future plans
  - Calibration
  - Off-site project engineering
  - Control and Logic diagrams
  - Cross-plant wiring
  - Design re-use

## SmartPlant Instrumentation Vision

---

- Improve and enhance support for integrated engineering work processes
- Provide advanced and reliable engineering and operations data management solutions for operating plants
- Respond to discipline specific business driven needs of the engineering community
- Extend SPI reach from traditional petrochemical industry to power, including nuclear, pharmaceuticals and mining
- Continue to improve reliability and usability of the application

## SmartPlant Instrumentation in 2007/2008

---

- Most of our customer base is migrating to v.7 and some v.2007 started but adoption is slow (v.2007 was released February 2007). Therefore new functionality being developed in v.2008 will provide positive impact in 2009 onward.
  - EPC's migrate to utilize new functionality but are constrained by O/O's who are frequently setting SPI version in project specification
  - Once O/O implements SPI upgrades typically span is 2 to 4
- At the same time there is a lot of opportunities – both small and large – to improve existing work processes and meet new market challenges in 2008 onward.
- Intergraph decided to selectively introduce new functionality in v.2007 service packs to attract users to upgrade and address some of their critical business needs. Development shifted accordingly delivering these throughout v.2007 SP's and reducing the scope of v.2008 scope.
- Additional focus of the v.2008 release is to add foundation for additional functionality to come – better support for internationalization, improved publish mechanism, newer technology (more .NET), etc.

## SmartPlant Instrumentation Product Update

---

- V2007.5 released June 12, 2008
  - Support PDF generation automation for IDEAL, integration document generation and batch printing in SPI without the need for Adobe or Ghostscript using internal library
  - Domain Explorer issues related to moving or replicating large data sets resolved
  - Typical Loop handles Foundation Fieldbus and Soft Tag classes in addition to conventional tags
  - Allow changing instruments from the Foundation Fieldbus to conventional tag classes (some limitations exists for now)
  - Calibration module redesigned providing, among other improvements, customizable data entry forms, multiple calibration profiles and more flexibility selecting different calibration types for the instrument.
  - Extend mapping for additional DDP attributes to transfer to SP3D (dry and wet weight and dimensional status).

## SmartPlant Instrumentation Product Update

---

- Important usability improvement with the roll-out of the SPLM v.2008
  - Citrix/Terminal server based deployment is a de-facto standard for large organizations geographically and organizationally spread and also for multi-contractor projects
  - Project organization and contract relationships required the host to have all licenses in a single license server pool.
  - SPLM v.2008 will allow using multiple license servers from a single Citrix server or farm by designating specific user, e.g. one EPC or maintenance group, to use licenses from a certain license server; this will be Citrix server management administrative function

## SmartPlant Instrumentation Product Update

---

- V2007.4 released January 2008
  - Integration ToDoList enhancements – ignore task and select related tasks
  - Support for Vista Business client, Office 2007 and Microsoft IE 7
  - Additional multi-strip wiring ESL report for complete wiring from selected panel to the field with or without control system connectivity
  - Extension to the DDP library with new groups supported by SP3D
  - Multiple additional fields in the specification module - 480 numeric and 100 long (255 characters) fields
- V2007.3 released October 2007
  - New improved bi-directional interface with Emerson DeltaV
  - First phase of support for NAMUR NE-100 vendor data exchange initiative
  - Remove limitation of 200 fields per browser view
  - Decrease the frequency of accessing INTOOLS.INI for improved performance on complex networks
- Several additional features were added in 2007 in v.2007 SP1 and SP2, updated documentation is now delivered with each service pack and TR's found internally and by customers are addressed

- V2007 SP4 – New multi-strip wiring ESL report

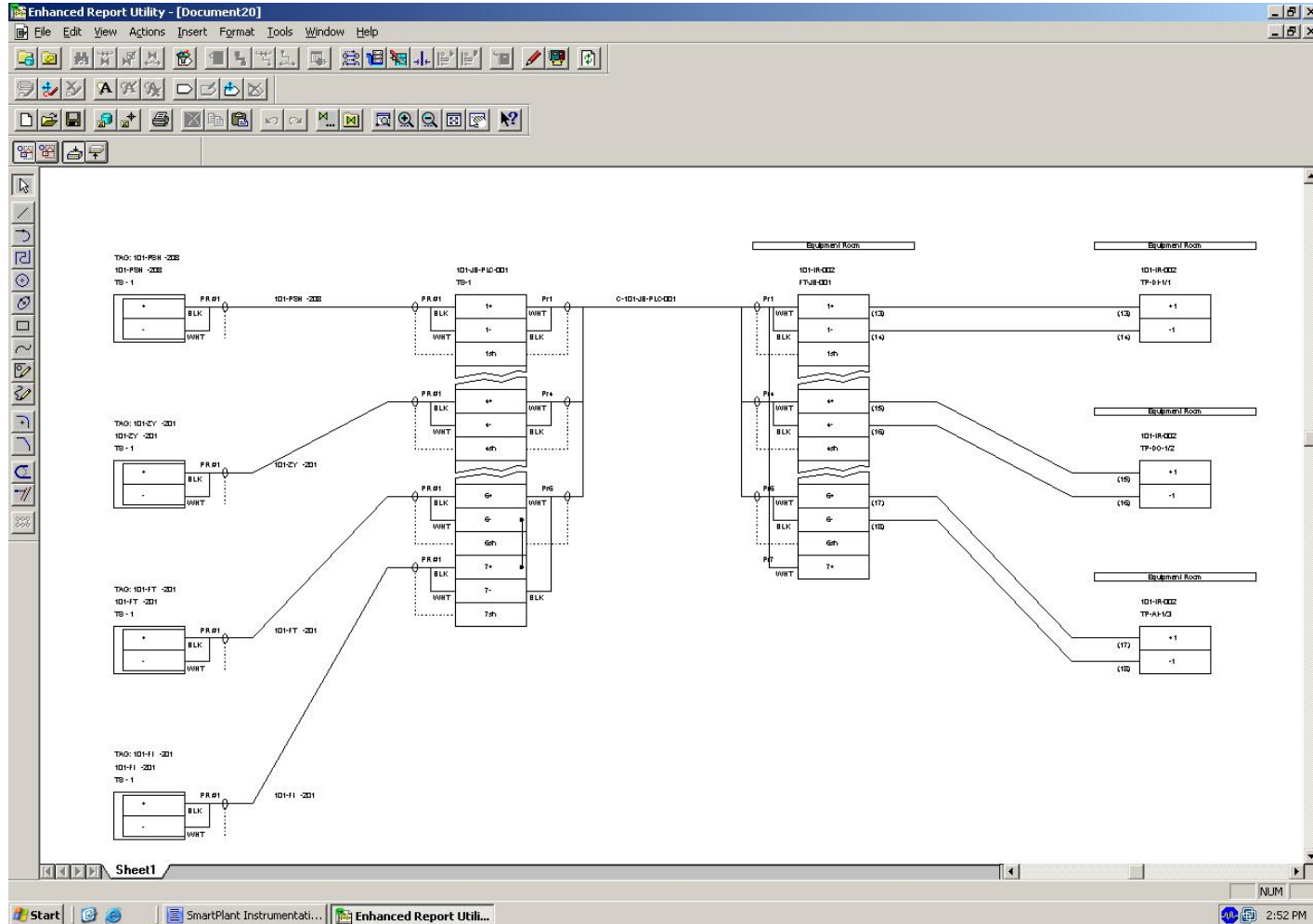

- V2007 SP4 – New multi-strip wiring ESL report

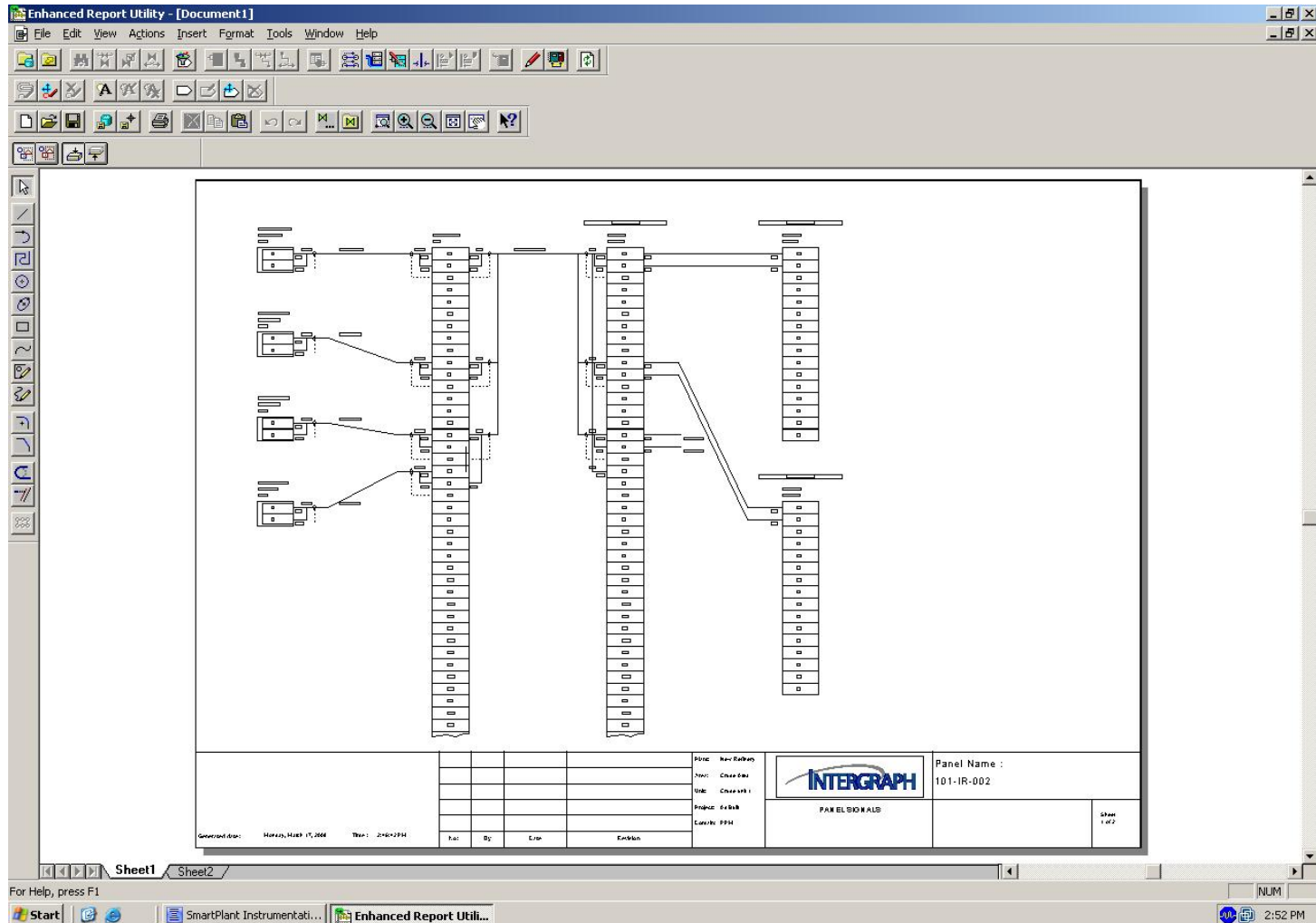

## SmartPlant Instrumentation Product Update

---

- Next major release - V2008

Scheduled release: Q4, 2008

- Support publishing all SPI engineering documents to integrated engineering environment
- Provide ability to publish all browsers with the content and filter what records are included in the published data set
- Support volumetric flow condition selection in the Instrument, Calibrated and DCS ranges across the application
- Provide complete Oracle Unicode database support
- New specifications library built on industry practices
- Improved database security and control capabilities
- Enable merging project entities into As Build without the need for exclusive use of the domain
- Support Citrix Presentation Server 4.5

- V2008 – New specifications library

101-FE -104 - 101-FE -104.isf

Page 1 | Page 2 | Notes

ADMINISTRATIVE IDENTIFICATIONS			SERVICE IDENTIFICATIONS continued		
2	Tag number	101-FE -104	68	Downstream pipe orientation	horizontal
3	Project number	1234	69	Available downstream length	5 pipe diameter
4	Project	DEMO	70	Downstream pipe material	304 S.S.
5	Plant	New Refinery	71	Downstream insulation	Standard process
6	Area	Crude Area	72	Local hazardous area class	NA Div/Zone NA
7	Unit name	Crude unit 1	73	Local hazardous area group	NA Temp class NA
8	Unit number	101	74	Remote hazardous area class	NA Div/Zone NA
9	NA	NA	75	Remote hazardous area group	NA Temp class NA
10	SERVICE IDENTIFICATIONS		76	Enviromental area	outdoor
11	Equipment	C-101	77	NA	NA
12	Service	This is the service description for FE-104	78	COMPONENT DESIGN CRITERIA	
13	PID/Reference dwg number	100-PID01-001	79	Criticality	Normal
14	Upstream line number	2"-C-1003-3C	80	Flowmeter bore type	Square Edge Orifice
15	Upstream pipe standard	ANSI Pipe spec AC300	81	Sizing pressure tapping style	flange tappings
16	Upstream line size	2 in	82	Standard for size calculation	ISO 5167-1
17	Downstream line schedule	80S	83	Orifice / Throat sizing material	316 S.S.
18	Upstream wall thickness	0.218 in	84	Discharge coefficient	0.61113
19	Upstream line inside diameter	1.939 in	85	Compensation style	NA
20	Upstream pipe material	304 S.S.	86	Min diameter ratio (d/D)	0.25 Max dia ratio 0.75
21	Fluid service	category M	87	Preferred characteristic curve	
22	Upstream line orientation	horizontal	88	Minimum required accuracy	0.2 % input span
23	Available upstream length	20 pipe diameter	89	Certification	FM
24	Downstream line number	2"-C-1003-3C	90	Test requirements	flow accuracy
25	Downstream pipe standard	ANSI Pipe spec AC300	91	Supply loss failure mode	NA
26	Downstream line size	2 in	92	Signal loss failure mode	NA
27	Downstream line schedule	80S	93	NA	NA
28	Downstream wall thickness	0.218 in	94	NA	NA

- V2008 – New specifications library

101-FE -104 - 101-FE -104.isf

Page 1 Page 2 Notes

29	PROCESS VARIABLES	MATERIAL FLOW CONDITIONS			Units
30	Flow Condition Identification	@ Minimum flow	@ Normal flow	@ Maximum flow	
31	Fluid State	Liquid	Liquid	Liquid	NA
32	Fluid Phase	Single phase	Single phase	Single phase	NA
33	Fluid name	Blow Down waste	Blow Down waste	Blow Down waste	NA
34	Volumetric flow @flow	5	7	10	m <sup>3</sup> /h @flow
35	Upstream gage pressure	2	2.2	2.3	bar gage
36	Temperature	44	47	50	°C
37	Viscosity	0.2	0.2	0.2	cP
38	Velocity	0.64155	0.89817	1.2831	m/s
39	Density	800	820	830	kg/m <sup>3</sup>
40	Density at base conditions				kg/m <sup>3</sup>
41	Liquid Specific gravity	0.80079	0.82081	0.83082	NA
42	Specific gravity at Base				NA
43	Gas/Vapor Specific gravity	NA	NA	NA	NA
44	Molecular mass	NA	NA	NA	NA
45	Compressibility	NA	NA	NA	NA
46	Specific heats ratio	NA	NA	NA	NA
47	Vapor gage pressure	0.9	0.9	0.9	bar gage
48	Critical gage pressure		1000		bar gage
49	Secondary phase State	NA	NA	NA	NA
50	Mass fraction vapor	NA	NA	NA	NA
51	Mass flow	NA	NA	NA	NA
52	Secondary phase density	NA	NA	NA	NA
53	Secondary phase liquid SG	NA	NA	NA	NA
54	Pressure loss	NA	317.67	1494.5	mmH2O 4°C
55	Pipe Reynolds number	NA	193249	NA	NA

- V2008 – New specifications library

Page 1 Page 2 Notes

ORIFICE FLANGE OR FITTING				METER TUBE continued			
1	Flange/Fitting type	orifice flange union		52	Coupling locations	6 in of downstream end	
2	Pressure tap style	pipe taps (2 1/2D and 8D)		53	Internal bore diameter	2.345 in	
3	End conn nominal size	2 in	Rating cl 300	54	Flow straightener type	sprengle straightener	
4	End conn termn type	flanged	Style NPT(F)	55	Pipe/Tube material	316 SST	
5	Flange facing finish	ANSI B16.5		56	Bolting material	NA	
6	End conn schedule no	80		57	Exterior coating material	primer paint only	
7	Press tap conn nom size	1/2 in	Style NPT(F)	58	End termination material	carbon steel	
8	Pressure tap orientation	on-center		59	Gasket material	asbestos free gasket	
9	Tap connection plug type	hex head pipe plug		60	NA	NA	
10	Centering/Dowel pins	alignment dowel pins		61	NA	NA	
11	Jack screw material	high strength		62	NA	NA	
12	Flange/Fitting material	carbon steel cast		63	PERFORMANCE CHARACTERISTICS		
13	Trim material	cobalt Alloy 6B		64	Max press at design temp	333 psi	gage
14	Bolting material	low temp Carbon steel		65	Max design temp	500 °F	
15	Gasket material	glass-filled PTFE		66	Min working temperature	-50 °F	Max 105 °C
16	Lubrication material	aerosol grease		67	flow coef uncertainty	1.25%	
17	flange adapter	2 bolt threaded		68	NA	NA	
18	NA	NA		69	NA	NA	
19	NA	NA		70			
20	NA	NA		71			
21	ORIFICE PLATE AND HOLDER						
47	Vapor gage pressure	0.9	0.9	0.9	bar	gage	
48	Critical gage pressure		1000		bar	gage	
49	Secondary phase State	NA	NA	NA	NA		
50	Mass fraction vapor	NA	NA	NA	NA		
51	Mass flow	NA	NA	NA	NA		
52	Secondary phase density	NA	NA	NA	NA		
53	Secondary phase liquid SG	NA	NA	NA	NA		
54	Pressure loss	NA	317.67	1494.5	mmH2O	4°C	
55	Pipe Reynolds number	NA	193249	NA	NA		

- V2008 – New specifications library

Page 1 Page 2 Notes

1 ORIFICE FLANGE OR FITTING				51 METER TUBE continued			
2	Flange/Fitting type	orifice flange union		52	Coupling locations	6 in of downstream end	
3	Pressure tap style	pipe taps (2 1/2D and 8D)		53	Internal bore diameter	2.345 in	
4	End conn nominal size	2 in	Rating cl 300	54	Flow straightener type	sprengle straightener	
5	End conn termn type	flanged	Style NPT(F)	55	Pipe/Tube material	316 SST	
6	Flange facing finish	ANSI B16.5		56	Bolting material	NA	
7	End conn schedule no	80		57	Exterior coating material	primer paint only	
8	Press tap conn nom size	1/2 in	Style NPT(F)	58	End termination material	carbon steel	
9	Pressure tap orientation	on-center		59	Gasket material	asbestos free gasket	
10	Tap connection plug type	hex head pipe plug		60	NA	NA	
11	Centering/Dowel pins	alignment dowel pins		61	NA	NA	
12	Jack screw material	high strength		62	NA	NA	
55	Pipe Reynolds number	NA	193249		NA	NA	
56 PROCESS DESIGN CONDITIONS				95 PROCESS DESIGN CONDITIONS Continued			
57	Design gage pressure min	-0.5	bar gage	96	Barometric abs pressure	1 atm(stand)	
58	Design gage pressure max	12	bar gage	97	Design ambient temperature min	-40 °C	Max 55 °C
59	Design temperature minimum	-40 °C		98	NA	NA	
60	Design temperature maximum	100 °C		99	MATERIAL PROPERTIES		
61	Limits on DP across flowmeter	3000	mmH2O 4°C	100	Critical temperature	1234 °C	
62	Full scale flow	15	m³/h @flow	101	NFPA health hazard	1	Flammability 2
63	Differential Press @ Full Scale	2500 mmH2O 4°C		102	NFPA Reactivity	0	Corrosive Yes
64	Base abs pressure	1	bar abs	103	Erosive	No	Toxic Yes
65	Base Temperature	15.5 °C		104	Build-up tendency	No	
66	Compressibility at Base	NA		105	Transparent	No	Colored Yes
				INSTRUMENT SPECIFICATION			
				Orifice Meter Tube			
				Form No: 104			
				Sheet <input type="text"/> of <input type="text"/>			
No	By	Date	Revision	Chk	Appd	Signed	Dwg No: <input type="text"/>
							Rev: <input type="text"/>

- V2008 – New specifications library

Page 1 | Page 2 | Notes

1	ORIFICE FLANGE OR FITTING			51	METER TUBE continued							
2	Flange/Fitting type	orifice flange union		52	Coupling locations	6 in of downstream end						
3	Pressure tap style	pipe taps (2 1/2D and 8D)		53	Internal bore diameter	2.345 in						
4	End conn nominal size	2 in	Rating cl 300	54	Flow straightener type	sprengle straightener						
5	End conn termn type	flanged	Style NPT(F)	55	Pipe/Tube material	316 SST						
6	Flange facing finish	ANSI B16.5		56	Bolting material	NA						
55	Flange Keyholes number	NA	193249	NA	NA	NA						
56	PROCESS DESIGN CONDITIONS			95	PROCESS DESIGN CONDITIONS Continued							
57	Des	Coupling nominal size	3/4 in	Rating	cl 300							
58	Des	101 CALIBRATIONS AND TEST			INPUT OR TEST		OUTPUT TYPE	OUTPUT SIGNAL or DISPLAY				
59	Des	102 Description		LRV or Type	URV or Setpoint	or DIRECTION	LRV	URV	Units			
60	Des	103 Flow rate	Diff press @ full scale	0	m	15	m <sup>3</sup> /h	@Flow	square root	0	2500	mmH2O 4°C
61	Lim	104 Test pressure	NA			123	psi	NA	NA			NA
62	Full	105										
63	Diff	106										
64	Bas	107										
65	Bas	108										
66	Cor	109	COMPONENT IDENTIFICATIONS									
		110	COMPONENT TYPE	MANUFACTURER			MODEL NO.					
		111	orifice plate-meter tube	DANIEL			DANIEL					
		112										
		113										
		114										
		115										
		116										
51	Mass											
52	Secon											
53	Secon											
54	Presst											
55	Pipe R											
INSTRUMENT SPECIFICATION												
Orifice Meter Tube												
Form No: 104										Sheet	of	
No	By	Date	Revision	Chk	Appd	Signed	Dwg No:			Rev:		

- V2008 – Support publishing almost all SPI engineering documents

Page 5-6 of 14

INTERGRAPH SmartPlant Instrumentation Functional design Issue 0.1			INTERGRAPH SmartPlant Instrumentation Functional design Issue 0.1		
72	Status History Report	Dimensional Data	240	Amplifier Actual Load Report	Wiring
71	Suspected Data Instrument List	Dimensional Data	241	Amplifier Speaker Load Report	Wiring
73	Suspected Status History	Dimensional Data	20	Cabinet	Wiring
70	Tag Dimensions List	Dimensional Data	246	Cable Block Diagram	Wiring
76	Vendor Dimensional Data	Dimensional Data	142	Cable Book	Wiring
27	Bill of Material	Hook-Ups	146	Cable Book (detailed)	Wiring
245	Enhanced Hook-Up	Hook-Ups	133	Cable Connector Take Off	Wiring
56	Hook-Up Item List	Hook-Ups	31	Cable Gland Take-Off	Wiring
54	Hook-Up Tag List	Hook-Ups	13	Cable Layout (Style 1)	Wiring
28	Library Items	Hook-Ups	46	Cable Layout (Style 2)	Wiring
96	All Tag Numbers Report - All <Units>	Instrument Index	29	Cable Schedule	Wiring
231	All Tag Numbers Report - Current <Area>	Instrument Index	162	Cable Schedule with Routing Data	Wiring
95	All Tag Numbers Report - Current <Unit>	Instrument Index	30	Cable Summary Take-Off	Wiring
203	Associated Electrical Equipment	Instrument Index	161	Cables Not Assigned to Drums	Wiring
205	Associated Schematic	Instrument Index	209	Comm. Line Report	Wiring
190	Available Tag Number Numeric Segments	Instrument Index	16	Control System Tag List	Wiring
83	Detailed Instrument Type List	Instrument Index	147	Cross Section List	Wiring
116	Drawing Report	Instrument Index	148	Cross Section List (detailed)	Wiring
84	Equipment Report	Instrument Index	198	DCS Channels Report	Wiring
85	Equipment Report - Grouping By Equipment Type	Instrument Index	196	Default Cable List	Wiring
155	Field Value Changes Report	Instrument Index	197	Default Panel List	Wiring
191	Function Blocks Report	Instrument Index	23	Device Cables	Wiring
82	Instrument Type Report	Instrument Index	135	Device Panel Connection Report	Wiring
86	Line Numbers Report	Instrument Index	17	Device Panel List (per <Plant>)	Wiring
87	Line Numbers Report - Grouping By Line Type	Instrument Index	49	Device Panel List (per <Unit>)	Wiring
93	Loop List Summary - All <Units>	Instrument Index	22	Distant DCS/PLC	Wiring
228	Loop List Summary - Current <Area>	Instrument Index	159	Drum List (unused cables)	Wiring
92	Loop List Summary - Current <Unit>	Instrument Index	156	Drum Schedule	Wiring
193	Loop List with No Tags Summary - All <Units>	Instrument Index	158	Drum Summary	Wiring
229	Loop List with No Tags Summary - Current <Area>	Instrument Index	247	Enhanced Multi-Strip Report	Wiring
192	Loop List with No Tags Summary - Current <Unit>	Instrument Index	248	Enhanced Multi-Strip Signal Report	Wiring
160	Loop Measured Variables Report	Instrument Index	239	Fieldbus Segment Validations Report	Wiring
157	Related Documents Report	Instrument Index	220	Harness Report	Wiring
94	Tag Numbers By Loops	Instrument Index	25	I/O Card Model Report	Wiring
128	Telecom Field Equipment	Instrument Index	26	I/O Card Type Report	Wiring
125	Telecom Line Numbers	Instrument Index	212	Internal Connections Report	Wiring
129	Telecom Signal Levels Report	Instrument Index	8	Intrinsically Safe	Wiring
127	Telecom Tag Numbers Report - All <Units>	Instrument Index	237	Junction Box	Wiring
230	Telecom Tag Numbers Report - Current <Area>	Instrument Index	19	Location Layout	Wiring
130	Telecom Tag Numbers Report - Current <Unit>	Instrument Index	211	Marshaling Rack	Wiring
62	Drawing Generation Report	Loop Drawings	144	Network Class Report	Wiring
67	Repair Details Report	Maintenance	24	Non - Used Section	Wiring
68	Scheduled Preventive Maintenance Report	Maintenance	21	Non-Device Cables	Wiring
65	Summary of Outcome	Maintenance	216	Non-Distant DCS/PLC	Wiring
64	Summary of Repair Actions	Maintenance	233	PA Amplifier Report	Wiring
66	Summary of Repair Reasons Report	Maintenance	138	Panel Layout	Wiring
139	Actual Load Report	Wiring	51	Panels By Network Class	Wiring
				Point to Point Wiring Diagram	Wiring

## SmartPlant Instrumentation Future Plans

---

- Future short term development plans
  - Improve support for the project engineering disconnected from the As Built databases – both in the SPI standalone use and in the integrated environments.
  - Develop engineering design re-use mechanism to support:
  - Continued improvements in the plant operational use like enhancing Calibration module and integrating with smart calibrator vendors
  - Support cross-plant wiring
  - Start developing control logic diagrams documentation capabilities
  - Continue enhancing and improving NE-100 interface to support vendor information exchange
  - Implement select additional new features with high demand

These and other features will be part of the future major releases and service packs.

## SmartPlant Instrumentation Future Plans

---

- Calibration module re-design

- Increasing availability of SPI data at the operating facilities
- Desire to have plant instrument management functionality included in SPI rather than integrated with additional systems
- ERP and CMMS systems are not very well fit to handle specifics and quantities of the instrumentation

All of this creates market demand and business opportunity

- Key changes:

- Customizable calibration forms – settings and results
- Multiple profiles available for instrument – set in the instrument type profile
- Test equipment is now part of the instrument index and allows tracking and calibration of test equipment.
- Calibration certificate – snapshot of the calibration results
- Errors per each calibration point are now explicitly recorded in the database (and not recalculated as before for reports) allowing for better analysis
- Increased intuitiveness of the work flow and individual operations

## SmartPlant Instrumentation Future Plans

- Calibration module re-design – Calibration profiles
  - Calibration forms are now customizable (InfoMaker) and allow selection of 2 forms – Calibration settings and Calibration Data entry

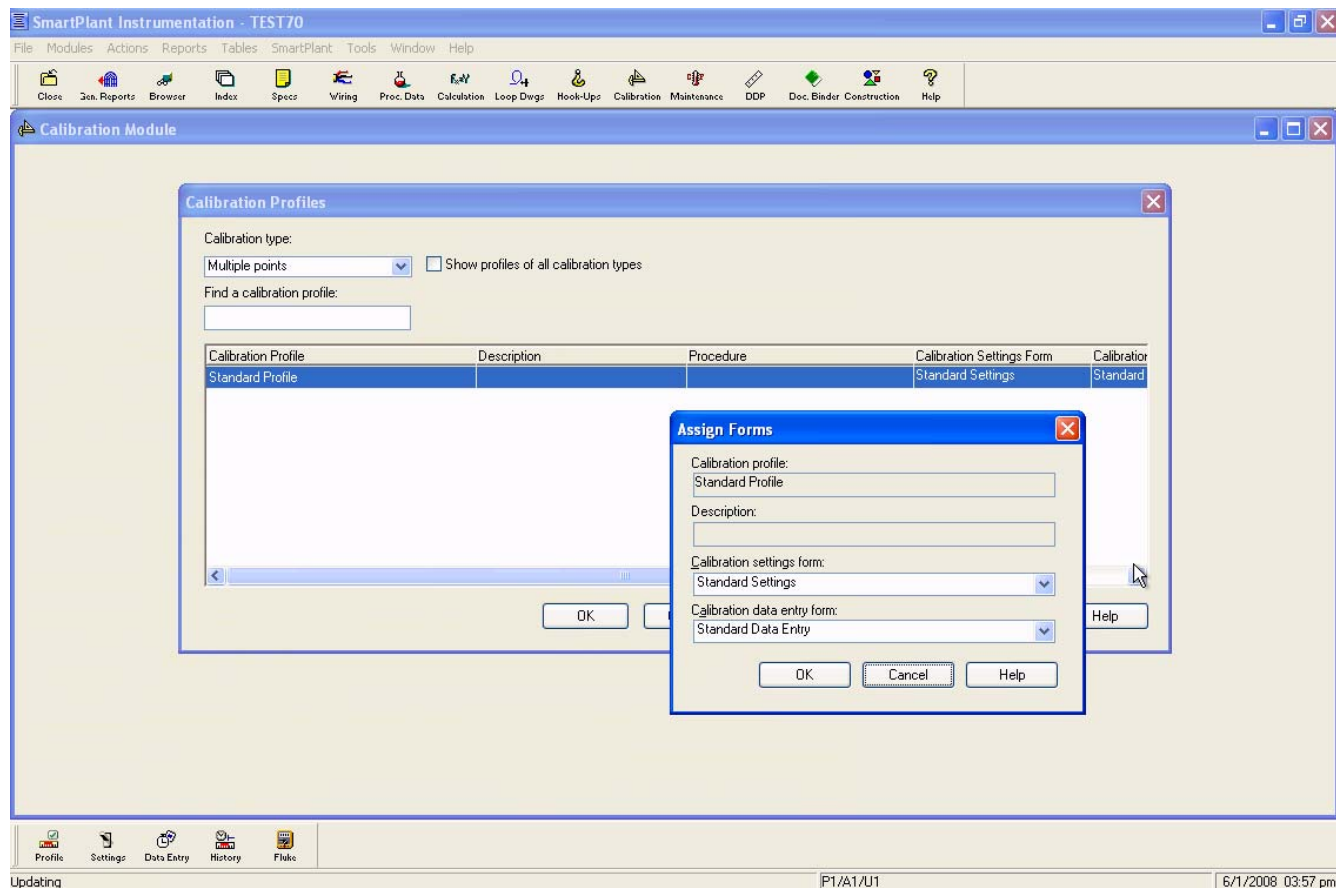

## SmartPlant Instrumentation Future Plans

- Calibration module re-design – Instrument type profiles
  - When multiple profiles are enabled on the instrument type, specific instrument can have *different* types of calibration as needed by maintenance

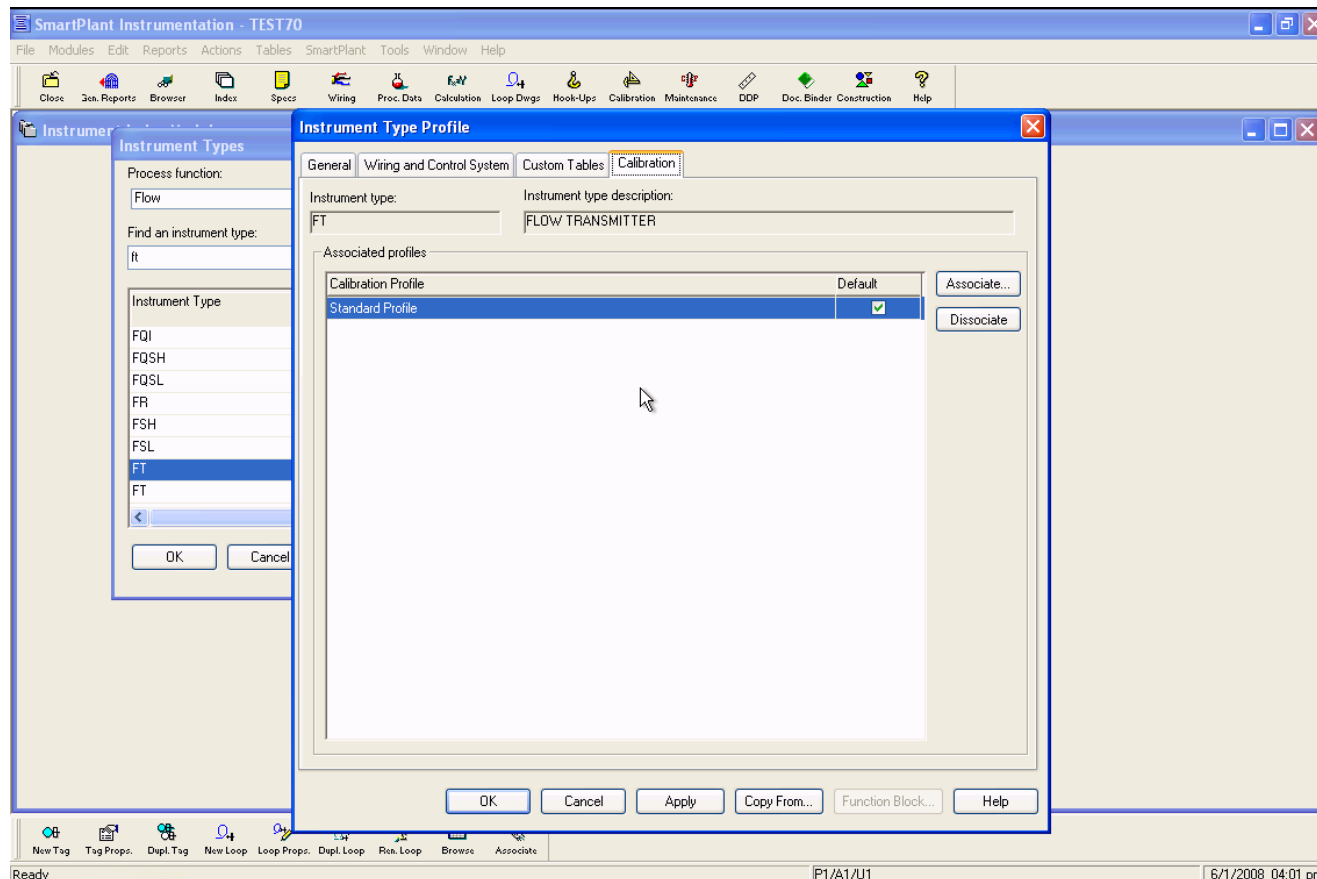

## SmartPlant Instrumentation Future Plans

- Calibration module re-design – Standard Profile
  - Similar to the default specifications a standard profile can be defined to reduce time to create individual instrument calibration settings.

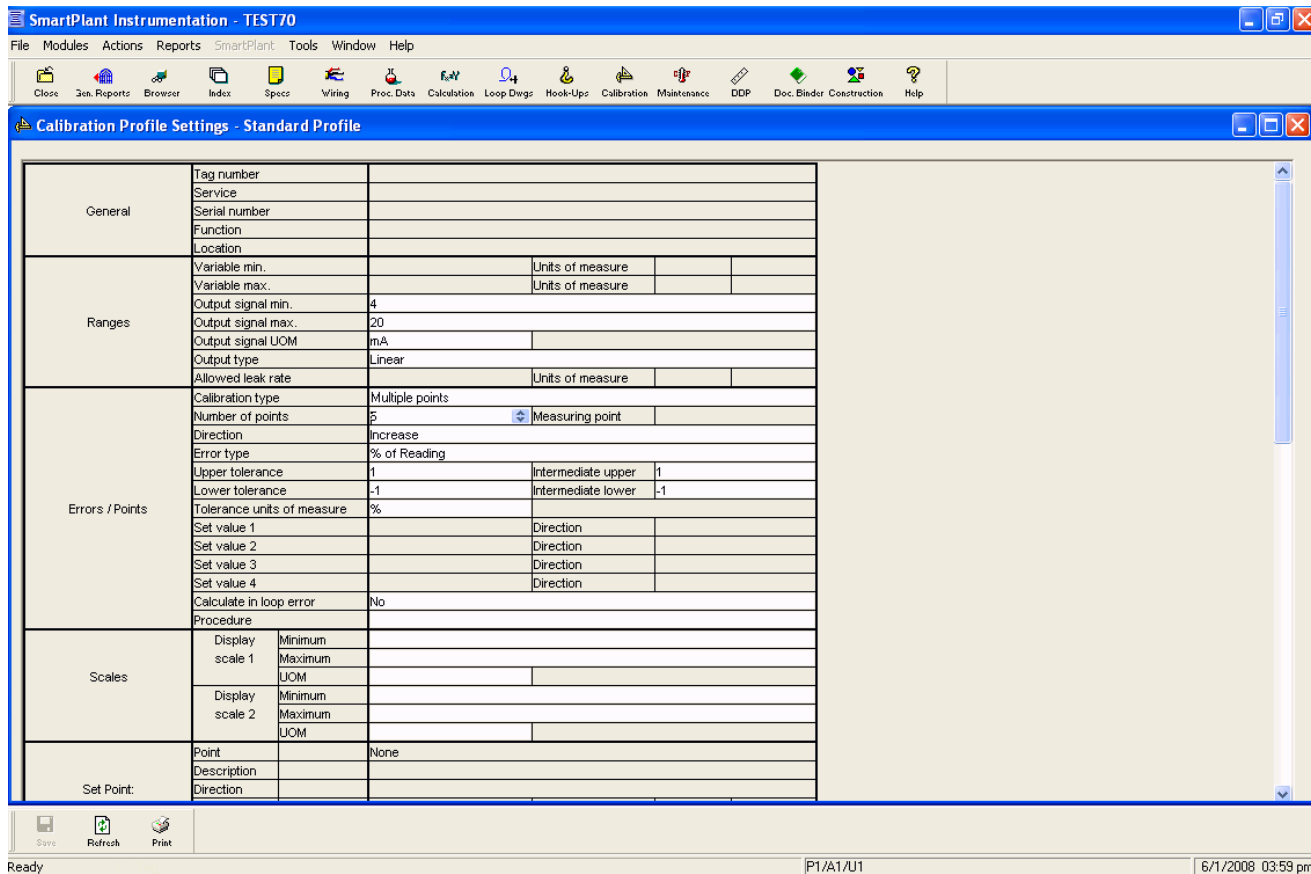

The screenshot shows the 'SmartPlant Instrumentation - TEST70' application window. The 'Calibration Profile Settings - Standard Profile' dialog box is open, displaying a table of configuration options for a standard calibration profile.

Category	Property	Value	Units of measure	Intermediate upper	Intermediate lower
General	Tag number				
	Service				
	Serial number				
	Function				
	Location				
Ranges	Variable min.		Units of measure		
	Variable max.		Units of measure		
	Output signal min.	4			
	Output signal max.	20			
	Output signal UOM	mA			
	Output type	Linear			
	Allowed leak rate		Units of measure		
Errors / Points	Calibration type	Multiple points			
	Number of points	5	Measuring point		
	Direction	Increase			
	Error type	% of Reading			
	Upper tolerance	1		1	
	Lower tolerance	-1		-1	
	Tolerance units of measure	%			
	Set value 1		Direction		
	Set value 2		Direction		
	Set value 3		Direction		
Set value 4		Direction			
Scales	Calculate in loop error	No			
	Procedure				
	Display scale 1	Minimum			
	Display scale 1	Maximum			
Set Point:	Display scale 1	UOM			
	Display scale 2	Minimum			
	Display scale 2	Maximum			
	Display scale 2	UOM			
Set Point:	Point	None			
	Description				
	Direction				

At the bottom of the dialog box, there are buttons for 'Save', 'Refresh', and 'Print'. The status bar at the bottom of the application window shows 'Ready', 'P1/A1/U1', and the date/time '6/1/2008 03:59 pm'.

## SmartPlant Instrumentation Future Plans

- Calibration module re-design – Test Equipment
  - New Tag class added to the instruments (tags) – **Test Equipment**

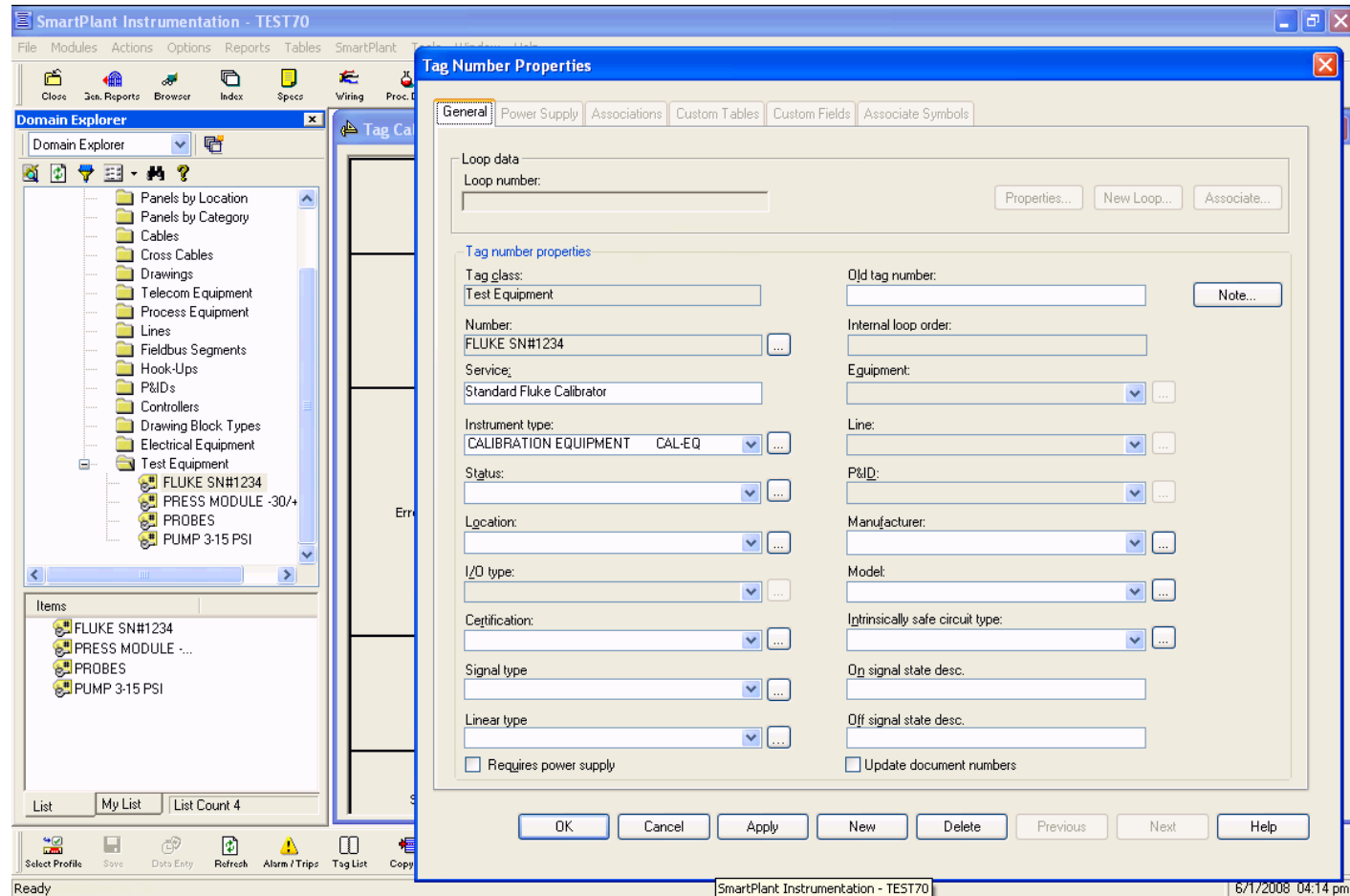

## SmartPlant Instrumentation Future Plans

- Calibration module re-design – Recording results
  - Codes, test equipment and result points are all available in one data entry form
  - Result points data is now vertical

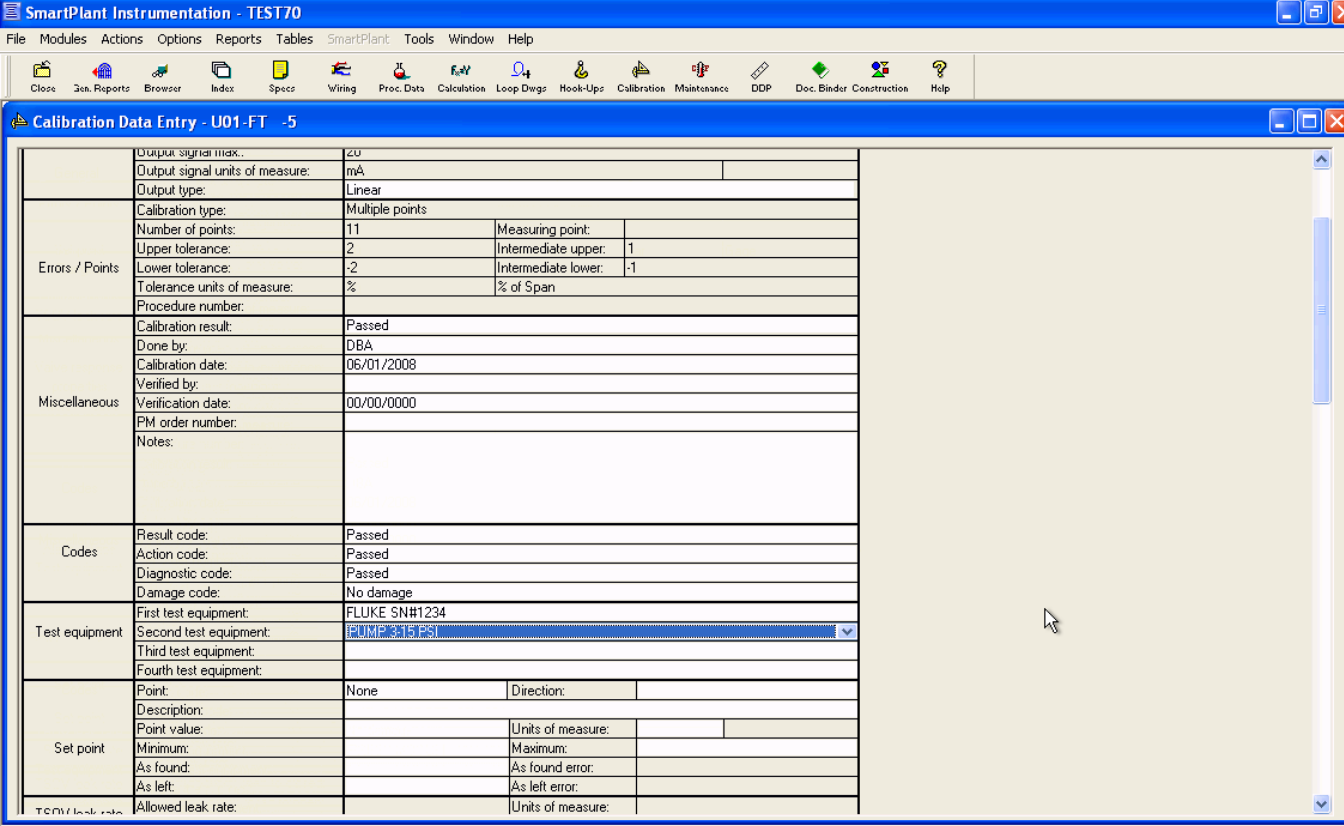

SmartPlant Instrumentation - TEST70

File Modules Actions Options Reports Tables SmartPlant Tools Window Help

Close Gen. Reports Browser Index Specs Wiring Proc. Data Calculation Loop Dvgs Hook-Ups Calibration Maintenance DDP Doc. Binder Construction Help

Calibration Data Entry - U01-FT -5

	Output signal max.:	20		
	Output signal units of measure:	mA		
	Output type:	Linear		
Errors / Points	Calibration type:	Multiple points		
	Number of points:	11	Measuring point:	
	Upper tolerance:	2	Intermediate upper:	1
	Lower tolerance:	-2	Intermediate lower:	-1
	Tolerance units of measure:	%	% of Span	
	Procedure number:			
Miscellaneous	Calibration result:	Passed		
	Done by:	DBA		
	Calibration date:	06/01/2008		
	Verified by:			
	Verification date:	00/00/0000		
	PM order number:			
Notes:				
Codes	Result code:	Passed		
	Action code:	Passed		
	Diagnostic code:	Passed		
	Damage code:	No damage		
Test equipment	First test equipment:	FLUKE SN#1234		
	Second test equipment:	FLUKE SN#1234		
	Third test equipment:			
	Fourth test equipment:			
Set point	Point:	None	Direction:	
	Description:			
	Point value:		Units of measure:	
	Minimum:		Maximum:	
	As found:		As found error:	
	As left:		As left error:	
	Allowed leak rate:		Units of measure:	

Ready P1/A1/U1 6/1/2008 04:12 pm

## SmartPlant Instrumentation Future Plans

- Calibration module re-design – Recording results
  - Codes, test equipment and result points are all available in one data entry form
  - Result points data is now vertical

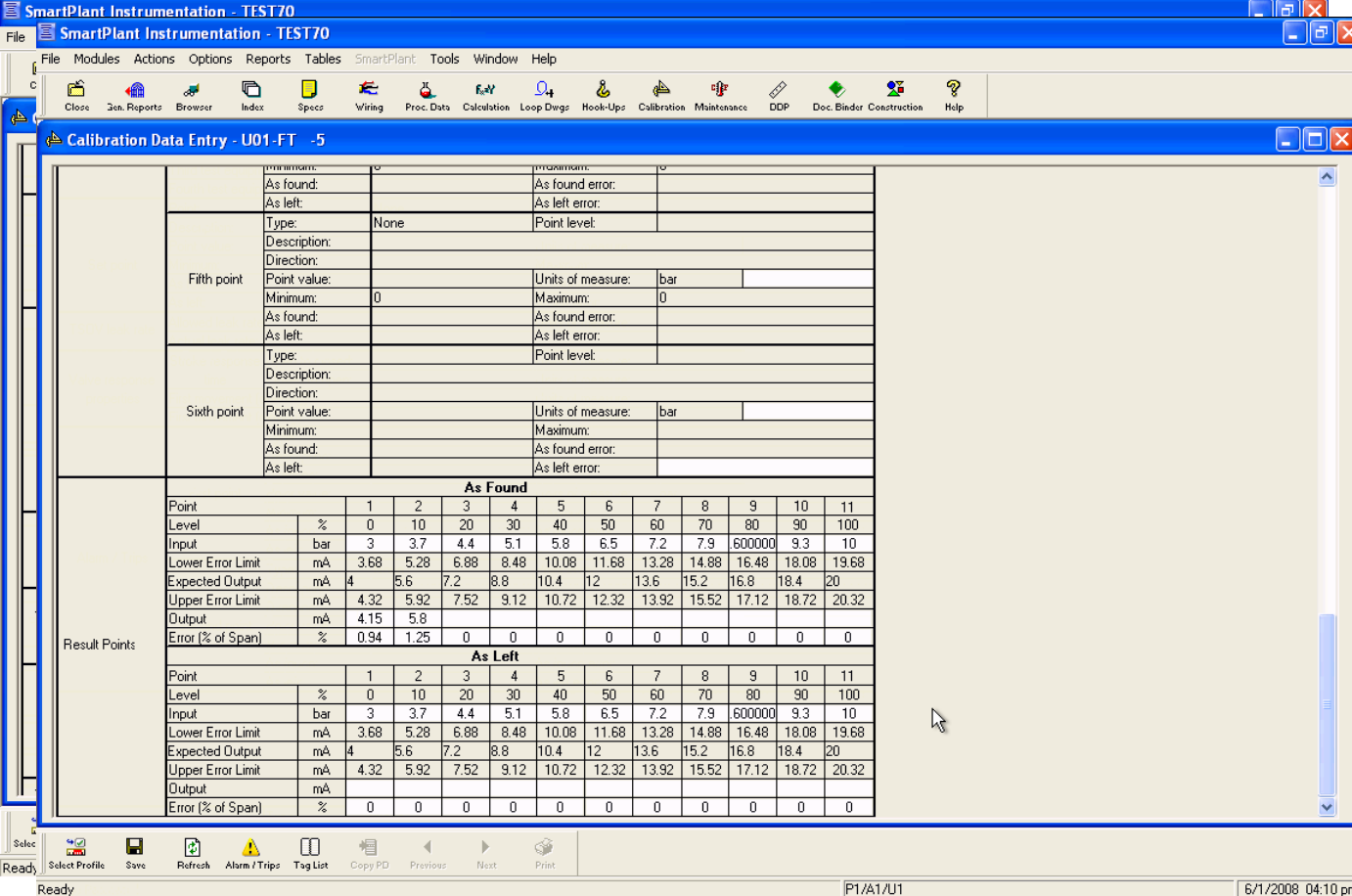

**SmartPlant Instrumentation - TEST70**

File Modules Actions Options Reports Tables SmartPlant Tools Window Help

Close Gen. Reports Browser Index Specs Wiring Proc. Data Calculation Loop Degr. Hook-Ups Calibration Maintenance DDP Doc. Binder Construction Help

**Calibration Data Entry - U01-FT -5**

Fifth point	As found:		As found error:	
	As left:		As left error:	
	Type:	None	Point level:	
	Description:			
	Direction:			
	Point value:		Units of measure:	bar
Minimum:	0	Maximum:	0	
As found:		As found error:		
As left:		As left error:		
Type:		Point level:		
Description:				
Direction:				
Point value:		Units of measure:	bar	
Minimum:		Maximum:		
As found:		As found error:		
As left:		As left error:		

**Result Points**

		As Found										
Point		1	2	3	4	5	6	7	8	9	10	11
Level	%	0	10	20	30	40	50	60	70	80	90	100
Input	bar	3	3.7	4.4	5.1	5.8	6.5	7.2	7.9	600000	9.3	10
Lower Error Limit	mA	3.68	5.28	6.88	8.48	10.08	11.68	13.28	14.88	16.48	18.08	19.68
Expected Output	mA	4	5.6	7.2	8.8	10.4	12	13.6	15.2	16.8	18.4	20
Upper Error Limit	mA	4.32	5.92	7.52	9.12	10.72	12.32	13.92	15.52	17.12	18.72	20.32
Output	mA	4.15	5.8									
Error (% of Span)	%	0.94	1.25	0	0	0	0	0	0	0	0	0

		As Left										
Point		1	2	3	4	5	6	7	8	9	10	11
Level	%	0	10	20	30	40	50	60	70	80	90	100
Input	bar	3	3.7	4.4	5.1	5.8	6.5	7.2	7.9	600000	9.3	10
Lower Error Limit	mA	3.68	5.28	6.88	8.48	10.08	11.68	13.28	14.88	16.48	18.08	19.68
Expected Output	mA	4	5.6	7.2	8.8	10.4	12	13.6	15.2	16.8	18.4	20
Upper Error Limit	mA	4.32	5.92	7.52	9.12	10.72	12.32	13.92	15.52	17.12	18.72	20.32
Output	mA											
Error (% of Span)	%	0	0	0	0	0	0	0	0	0	0	0

Ready | Select Profile | Save | Refresh | Alarm / Trips | Tag List | Copy PD | Previous | Next | Print | P1/A1/U1 | 6/1/2008 04:10 pm

## SmartPlant Instrumentation Future Plans

- Calibration module re-design – Calibration certificate
  - Similar to the MER results, calibration results are now recorded in 2 forms – data and BLOB snapshot for permanent recording and reported as Calibration certificate

Print Preview - Calibration Certificate Report					
General	Tag number:	U01-FT -5			
	Service:				
	Serial number:				
	Function:	FLOW TRANSMITTER			
	Location:				
Ranges	Variable min.:	3	Units of measure:	bar	Gage
	Variable max.:	10	Units of measure:	bar	Gage
	Output signal min.:	4			
	Output signal max.:	20			
	Output signal units of measure:	mA			
	Output type:	Linear			
Errors / Points	Calibration type:	Multiple points			
	Number of points:	10	Measuring point:		
	Upper tolerance:	2	Intermediate upper:	1	
	Lower tolerance:	-2	Intermediate lower:	-1	
	Tolerance units of measure:	%	% of Span		
	Procedure number:				
Miscellaneous	Calibration result:	Failed			
	Done by:	DBA			
	Calibration date:	05/28/2008			
	Verified by:	joe			
	Verification date:	00/00/0000			
	PM order number:				
Codes	Notes:	no damage found.			
	Result code:	Bad Result			
	Action code:	Passed			
	Diagnostic code:	Passed			
	Damage code:	No damage			
	First test equipment:	FLUKE SN#1234			

## SmartPlant Instrumentation Future Plans

- Calibration module re-design – Calibration certificate
  - Similar to the MER results, calibration results are now recorded in 2 forms – data and BLOB snapshot for permanent recording and reported as Calibration certificate

Print Preview - Calibration Certificate Report

Fifth point	Point value:		Units of measure:	
	Minimum:	0	Maximum:	0
	As found:		As found error:	
	As left:		As left error:	
Sixth point	Type:		Point level:	
	Description:			
	Direction:			
	Point value:		Units of measure:	
	Minimum:		Maximum:	
	As found:		As found error:	
	As left:		As left error:	

As Found												
Point		1	2	3	4	5	6	7	8	9	10	11
Level	%	0	25	50	75	100	100	75	50	25	0	
Input	bar	3	4.75	6.5	8.25	10	10	8.25	6.5	4.75	3	
Lower Error Limit	mA	3.68	7.68	11.68	15.68	19.68	19.68	15.68	11.68	7.68	3.68	
Expected Output	mA	4	8	12	16	20	20	16	12	8	4	
Upper Error Limit	mA	4.32	8.32	12.32	16.32	20.32	20.32	16.32	12.32	8.32	4.32	
Output	mA	4.3	8.08	11.85	15.65	19.9542	20.2154	16.32	12.22	10.9999	4.023	
Error (% of Span)	%	1.88	0.5	-0.94	-2.19	1.35	2	1.38	0.69	0.14		

As Left												
Point		1	2	3	4	5	6	7	8	9	10	11
Level	%	0	25	50	75	100	100	75	50	25	0	
Input	bar	3	4.75	6.5	8.25	10	10	8.25	6.5	4.75	3	
Lower Error Limit	mA	3.68	7.68	11.68	15.68	19.68	19.68	15.68	11.68	7.68	3.68	
Expected Output	mA	4	8	12	16	20	20	16	12	8	4	
Upper Error Limit	mA	4.32	8.32	12.32	16.32	20.32	20.32	16.32	12.32	8.32	4.32	
Output	mA	4.1105	8.05	11.96	16.21	20	20.04	16.08456	12.14	8.13	4.04	
Error (% of Span)	%	0.69	0.31	-0.25	1.31	0	0.25	0.53	0.88	0.61	0.25	

Result Points

## SmartPlant Instrumentation Future Plans

---

- Improve support for off-line project engineering

Solid and proven solution exists today for on-line project work-sharing / collaboration and for facilities plant engineering using Citrix or Terminal Server

There are still a number of challenges with this approach:

- IT infrastructure and security
- Communications infrastructure reliability and bandwidth availability in some regions
- Contractual and administrative

Alternatives are:

- Use of the merger utility
  - Requires highly skilled and experienced knowledge and is not a tool for engineers
  - Sensitive to the data integrity
- Use of the Off-line As Built functionality

## SmartPlant Instrumentation Future Plans

---

- Improve support for off-line project engineering - continued

Off-line As built project allow to

1. Create an engineering project in the O/O host domain
2. Export and send a back-up to initialize off-site domain containing Off-site baseline (As Built) and off-site project
3. Execute project off-site and import it back into host domain to merge into host As Built

Planned improvements in the Off-line As Built project functionality will address several issues with the current technology including:

- Re-scoping of the off-site project
- Synchronizing reference data between host and off-site domain
- Intellectual property protection removing process data and other sensitive information from the As built portion of the exported data
- Ability to convert EPC domain into engineering project and merge it back into the As Built

## SmartPlant Instrumentation Future Plans

- Develop Control and Logic diagramming capability
  - Add 2 new types of documents – Logic diagrams and Control diagrams

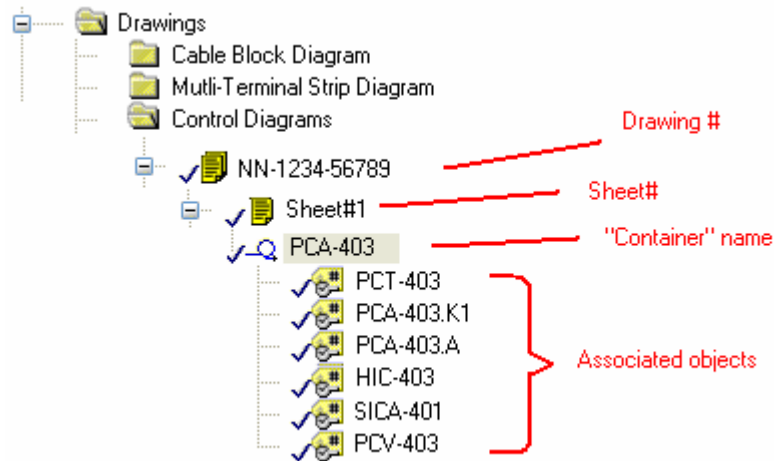

- Associated objects can include Loop, instruments (conventional, soft tags, Fieldbus, etc), control system tags and I/O channels
- Document (drawing) will be a combination of a number of containers arranged in sheets.

## SmartPlant Instrumentation Future Plans

- Develop Control and Logic diagramming capability - continued
  - Container will represent section of the logic

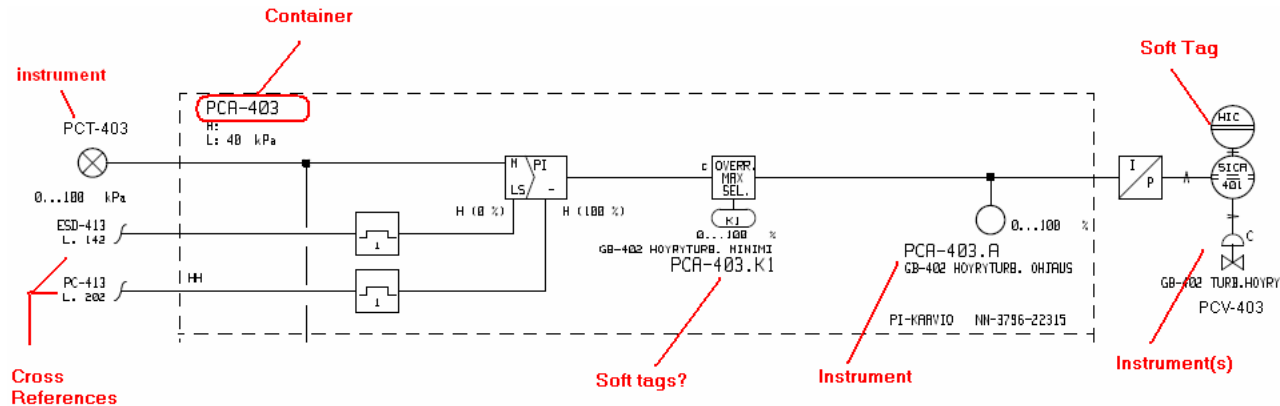

- Cross references will allow using Off Page Connectors (OPC) to reference other containers on the same or different pages of the document or in different document.

- Develop Control and Logic diagramming capability - continued
  - Container content will be created in a graphic environment

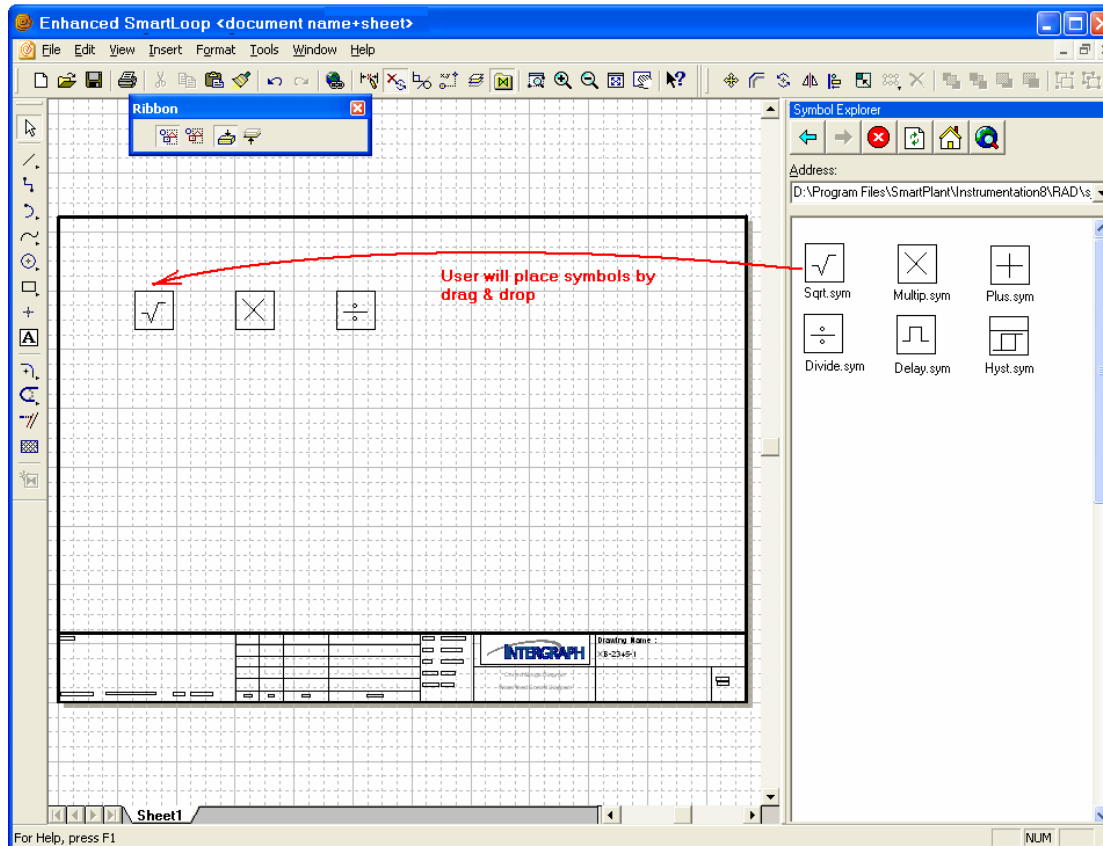

## SmartPlant Instrumentation Future Plans

- Develop Control and Logic diagramming capability - continued
  - Container content will be created in a graphic environment

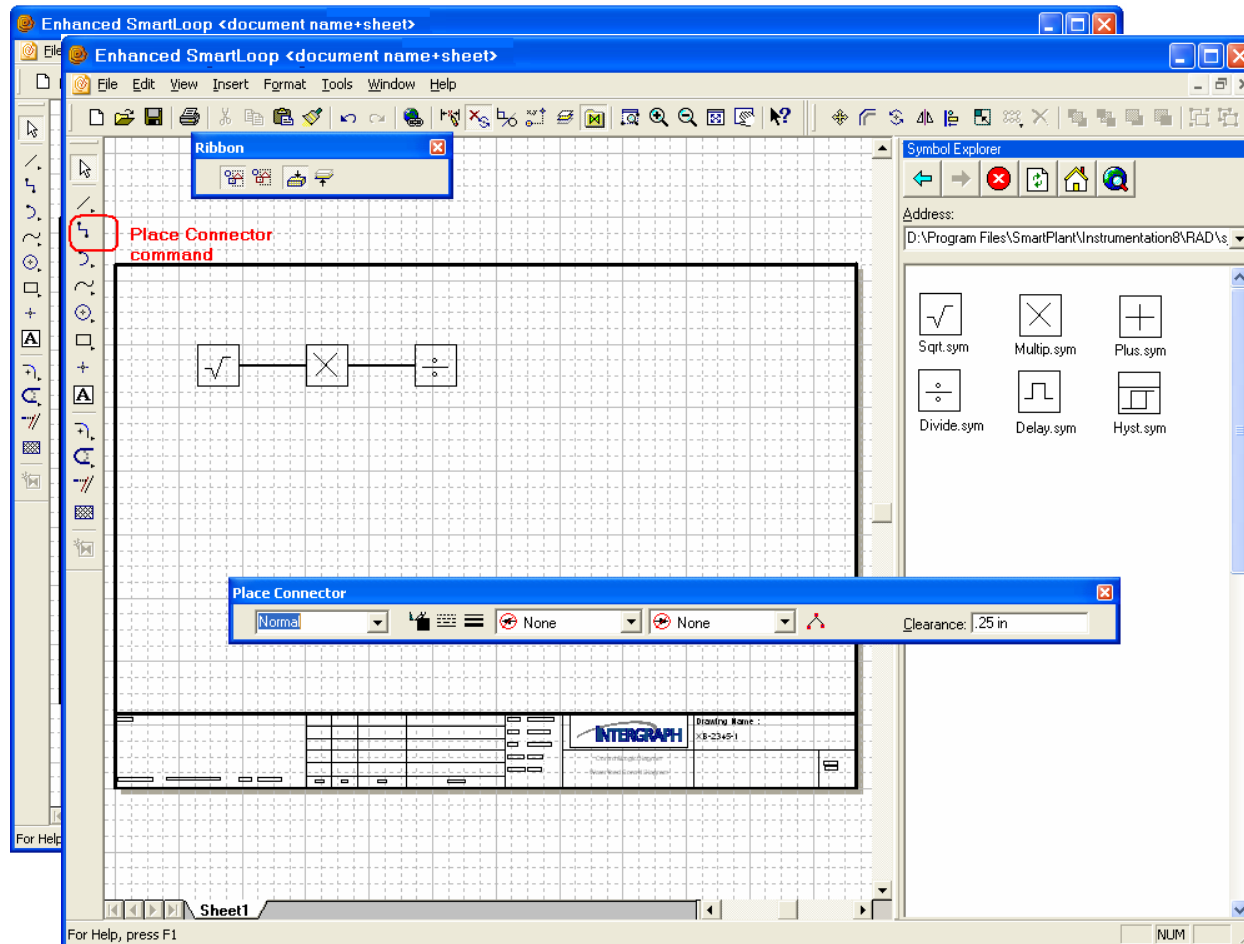

## SmartPlant Instrumentation Future Plans

---

- Design re-use

Seeking solution to the following business challenges

- Reuse of standard/typical design packages between projects
- Packaged vendor equipment instrument information delivery
- Licenser and pre-FEED packages transition to FEED and detailed design

- Requirements

- Engineers tools
- Ability to extract portions of design (groups of loops/tags and associated reference information) to a database neutral format for storage and reuse
- Ability to translate/map package item tag names(loop, component, etc) to target domain naming conventions
- And much more to be considered...

## SmartPlant Instrumentation Future Plans

- Cross plant wiring and reporting

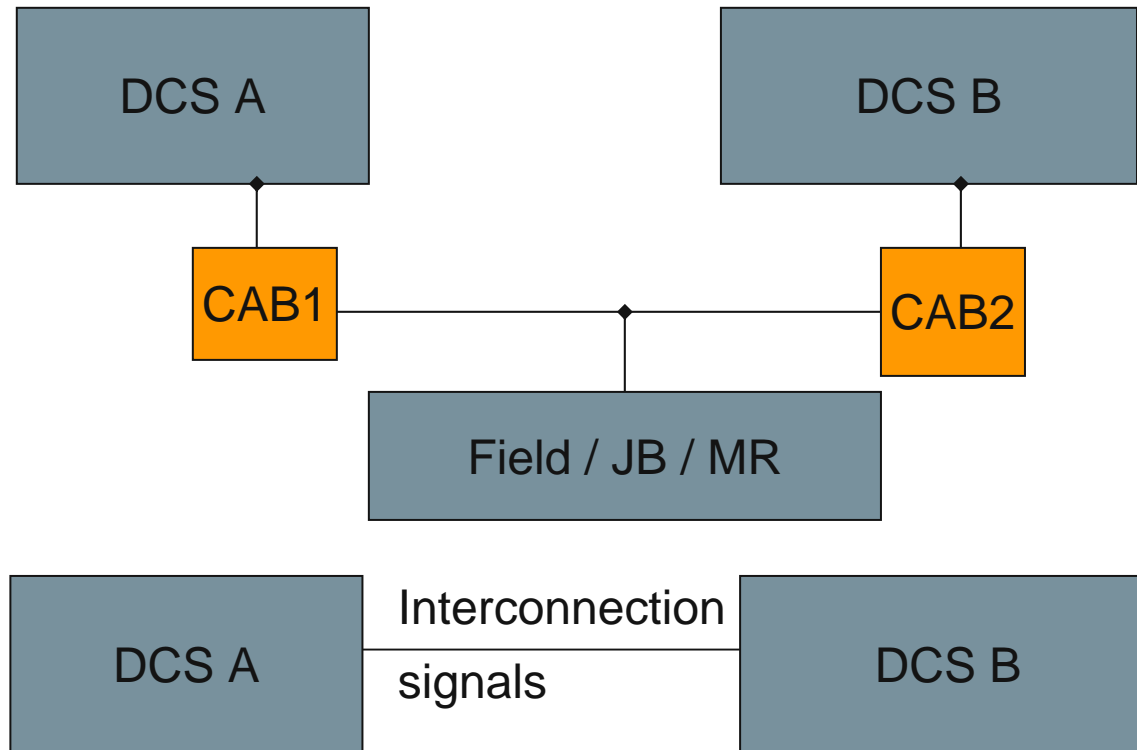

- Control system tags from different plants can be linked to one instrument creating cross-plant entity relationship
- Especially designated shared wiring entities – cables and/or panels

Thank you for being loyal  
SmartPlant Instrumentation (INtools)  
customers.